

Ersatzteilliste Spare Parts List

10/97

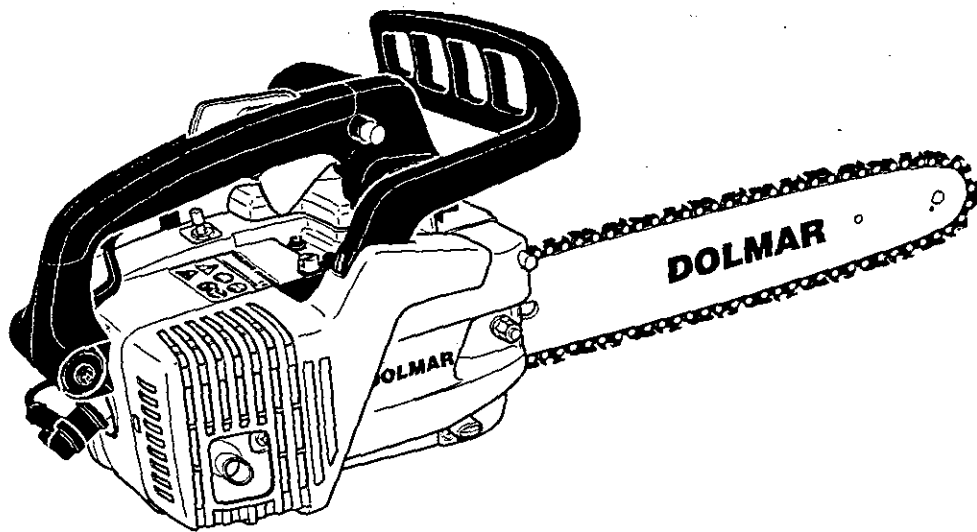

PS-3300 TH

DOLMAR



995 700 056 (D, GB)

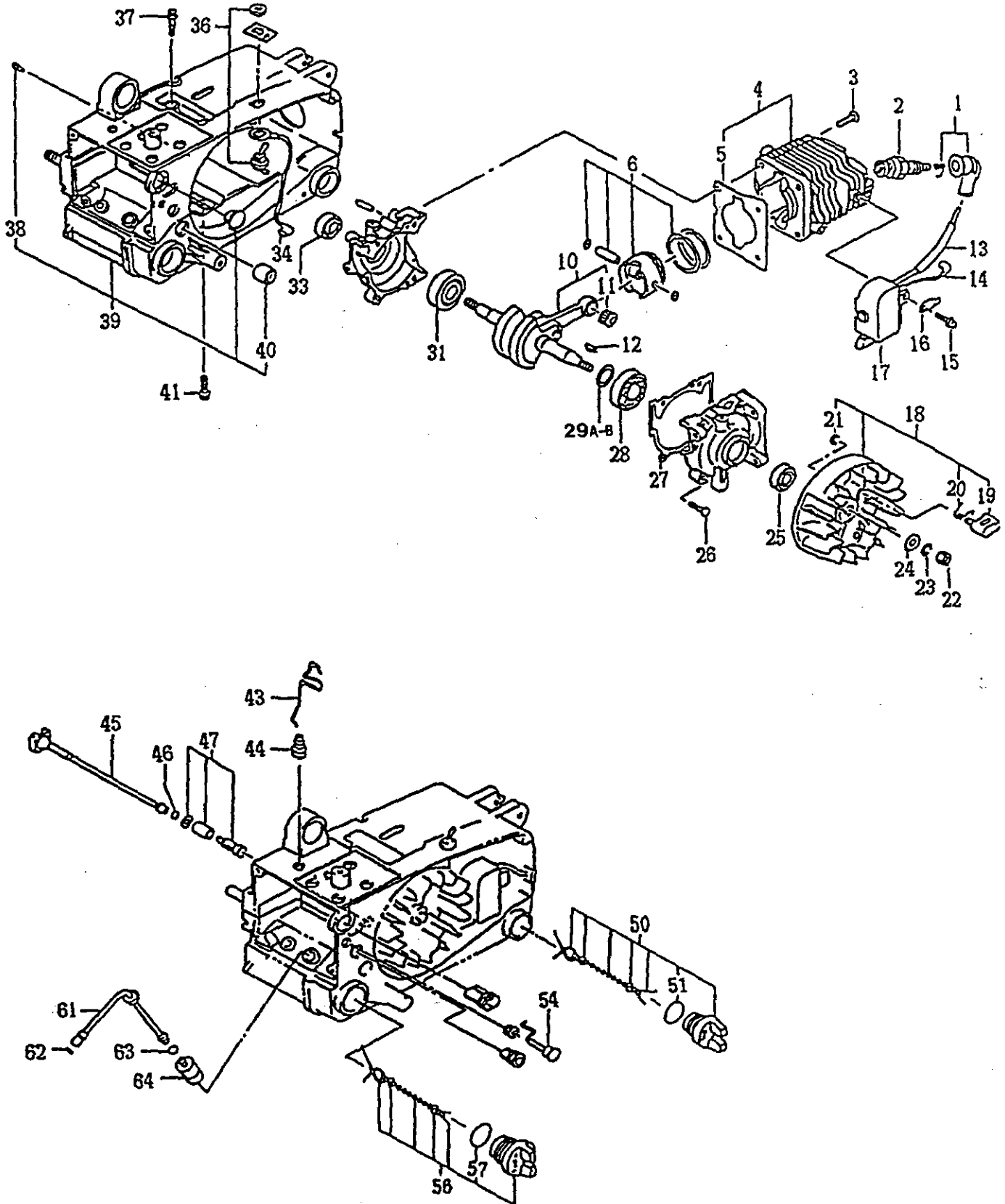



Pos.	Anz. Qty.	Teil-Nr. Part No.	Hinweise Notes	Benennung	Description
1	1	318 000 010		Zündkerzenstecker	Spark plug cap
2	1	965 603 017		Zündkerze	Spark plug
3	4	318 000 040		Schraube 5x16	Pan head screw
4	1	318 000 030		Zylinder kpl.	Cylinder set
5	1	318 000 050		Zylinderdichtung	Cylinder packing
6	1	318 000 070		Kolben kpl.	Piston set
10	1	318 000 100		Kurbelwelle	Crankshaft
11	1	318 000 110		Nadelkäfig	Needle cage
12	1	318 000 120		Scheibenfeder	Woodruff key
13	1	318 000 360		Isolierschlauch	Insulation tube
14	1	318 000 400		Kurzschlußkabel	Cord
15	1	318 000 230		Schraube 4x18 (WS)	Pan head screw
16	1	318 000 240		Kontaktblech	Tab
17	1	318 000 250		Zündanker	Ignition coil
18	1	318 000 190		Polrad kpl.	Flywheel assy.
19	2	318 000 200		Anwerfklinke	Starter ratchet
20	2	318 000 210		Drehfeder	Spring
21	2	318 000 220		Sicherungsscheibe 4	E-stop ring
22	1	318 000 160		Mutter	Nut
23	1	318 000 170		Federscheibe 7	Spring washer
24	1	318 000 180		Scheibe 7	Washer
25	1	318 000 280		Radialdichtring	Oil seal
26	4	318 000 260		Schraube 5x20 S	Pan head screw
27	1	318 000 290		Kurbelgehäusedichtung	Crankcase packing
28	1	960 102 129		Kugellager 6201	Ball bearing
29	1	318 000 130		Ausgleichscheibe 0,1	Shim
29a	1	318 000 140		Ausgleichscheibe 0,2	Shim
29b	1	318 000 150		Ausgleichscheibe 0,3	Shim
31	1	960 102 129		Kugellager 6201	Ball bearing
33	1	318 000 280		Radialdichtring	Oil seal
34	1	318 000 390		Massekabel	Grounding cord
36	1	318 000 370		Kurzschlußschalter	Stop switch assy.
37	1	318 000 350		6kt-Schraube 5x20	Hex. socket head bolt
38	1	318 000 330		Belüftungsventil	Ventilating valve
39	1	318 002 270		Motorgehäuse kpl.	Engine case assy.
40	1	318 000 340		Stopfen	Tank cap assy.
41	1	318 000 350		6kt-Schraube 5x20	Hex. socket head bolt
43	1	318 000 750		Gasgestänge	Throttle rod
44	1	318 000 760		Führung	Throttle guide
45	1	318 000 700		Ölleitung (B)	Oil pipe
46	1	318 000 710		Klemme	Clip
47	1	318 000 740		Ölfilter kpl.	Oil filter body assy.
50	1	318 000 830		Öltankverschluß kpl.	Oil tank plug assy.
51	1	318 000 840		O-Ring ø 18 mm	O-ring
54	1	318 000 870		Chokestange	Choke button
56	1	318 000 900		Tankverschluß kpl. (Kraftst.)	Tank plug assy. (fuel)
57	1	318 000 890		O-Ring ø 20 mm	O-ring
61	1	318 000 790		Kraftstoffleitung	Rubber pipe
62	1	318 000 710		Klemme	Clip
63	1	318 000 710		Klemme	Clip
64	1	318 000 800		Saugkopf (Kraftstoff)	Suction head (fuel)

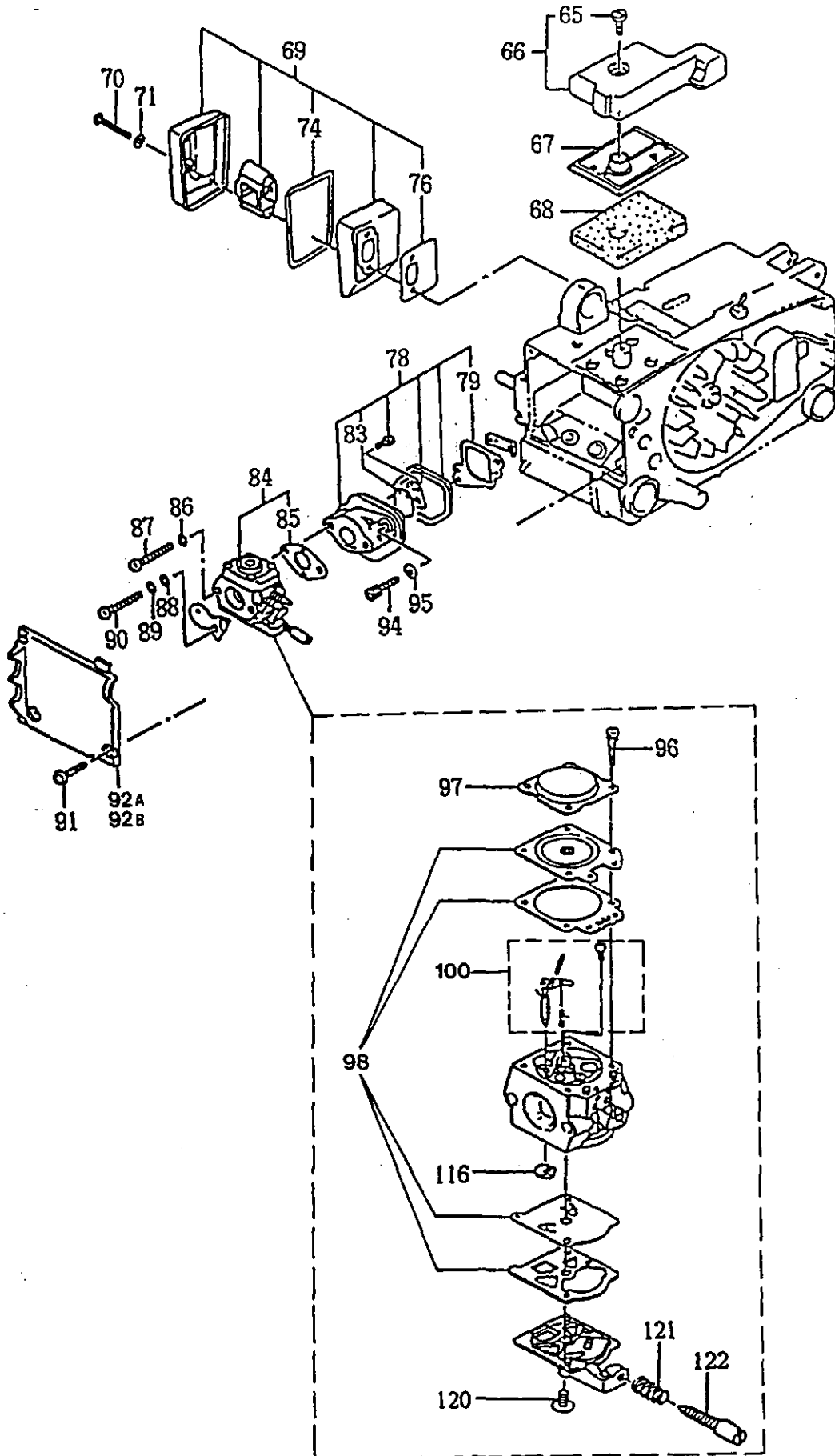

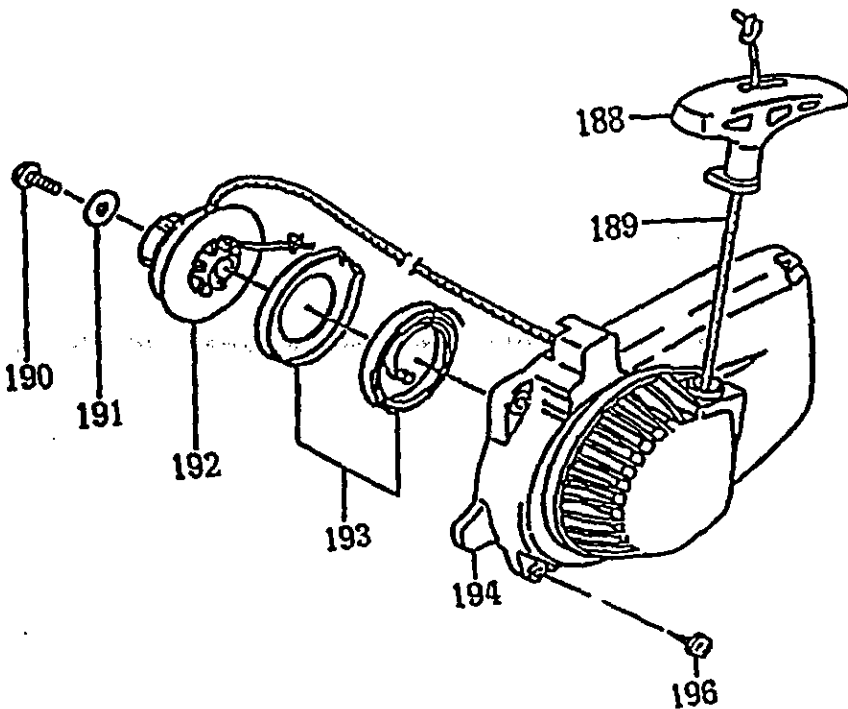
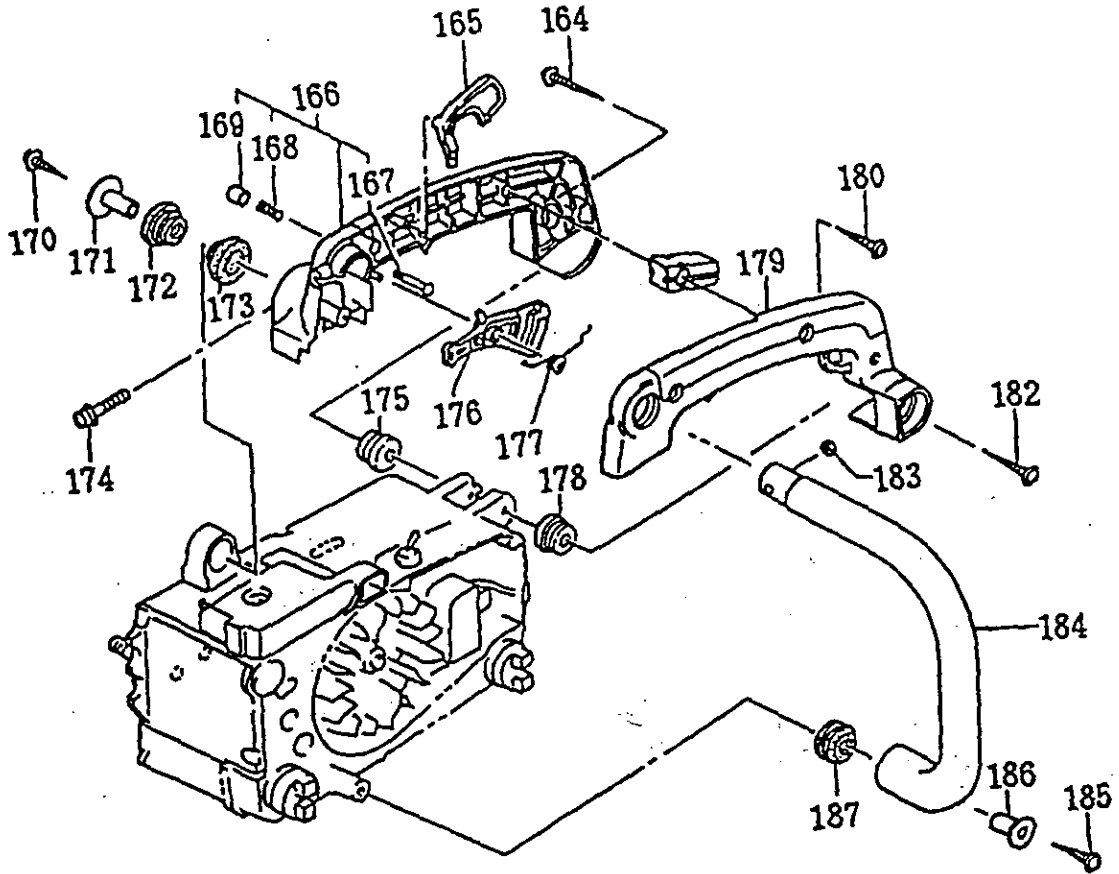

PS-3300 TH

4

Anwerfvorrichtung, Griffe
Starter, handles**DOLMAR**

Pos.	Anz. Qty.	Teil-Nr. Part No.	Hinweise Notes	Benennung	Description
164	1	318 000 920		Schraube 5x14	Screw
165	1	318 001 820		Rasthebel	Safety lever
166	1	318 001 780		Bedienungshandgriff (B)	Rear handle
167	1	318 001 810		Raststift	Push pin
168	1	318 001 800		Druckfeder	Stopper spring
169	1	318 001 790		Knopf	Push pin cap
170	1	318 001 730		Schraube 5x40	Screw
171	1	318 001 740		Befestigungsbuchse (A)	Damper collar
172	1	318 001 750		Schwingungsdämpfer (A)	Damper
173	1	318 001 750		Schwingungsdämpfer (A)	Damper
174	1	318 001 760		Schraube 4x30 PS	Pan head screw
175	1	318 002 250		Schwingungsdämpfer kpl.	Damper cpl.
176	1	318 001 830		Gashebel	Throttle lever
177	1	318 001 840		Feder	Throttle lever spring
178	1	318 002 250		Schwingungsdämpfer kpl.	Damper cpl.
179	1	318 001 850		Bedienungshandgriff (A)	Rear handle
180	1	318 001 710		Schraube 4x15	High-low screw
182	1	318 000 920		Schraube 5x14	Screw
183	1	318 001 720		Mutter 4	Nylon nut
184	1	318 001 880		Bügelgriff	Front handle
185	1	318 001 860		Schraube 5x35	Screw
186	1	318 001 900		Befestigungsbuchse (B)	Damper collar
187	1	318 001 890		Schwingungsdämpfer (B)	Damper
188	1	383 500 102		Anwerfgriff	Starter handle
189	1	381 500 206		Anwerfseil ø3x900mm	Starter rope
190	1	318 000 920		Schraube 5x14	Screw
191	1	318 000 930		Scheibe 1,6	Washer
192	1	318 000 940		Seiltrommel	Starter pulley
193	1	318 000 960		Rückholfeder	Rewind spring
194	1	318 002 290		Ventilatorgehäuse	Fan case assy.
196	4	318 000 990		Schraube 4,5x20	Screw

PS-3300 TH

5

Kettenbremse, Kupplung, Sägeschiene, Sägekette, Werkzeug
Chain brake, clutch, guide bar, saw chain, tools**DOLMAR**

Pos.	Anz. Qty.	Teil-Nr. Part No.	Hinweise Notes	Benennung	Description
124	1	923 208 004		6kt-Mutter M8	Hexagonal nut
126	1	318 002 300		Kettenradschutz	Side cover assy.
127	1	318 001 670		Buchse	Sleeve
129	1	318 001 700		Feder	Brake lever spring
130	1	318 001 600		Handschutz	Brake handle
132	1	318 001 640		Zylinderstift ø3x9,8	Needle roller
133	1	318 001 660		Bremsband	Brake spring
134	1	318 001 650		Bremsmechanik	Brake link
135	1	318 001 680		Hülse	Collar
136	1	318 001 620		Feder	Spring
137	3	318 001 710		Schraube 4x15	High-low screw
				Sägekette 3/8"	Saw chain 3/8"
138	1	528 092 046		Sägekette 30 cm	Saw chain 12"
138	1	528 092 052		Sägekette 35 cm	Saw chain 14"
				Sternschiene 3/8"	Sprocket nose bar 3/8"
139	1	412 030 661		Sternschiene 30 cm	Sprocket nose bar 12"
139	1	412 035 661		Sternschiene 35 cm	Sprocket nose bar 14"
140	1	318 001 290		Kupplung kpl.	Clutch
140a	2	318 001 460		Zugfeder	Clutch spring
141	1	318 001 300		Nadelkäfig	Needle bearing
142	1	318 001 310		Kupplungstrommel	Clutch drum
143	1	318 001 320		Anlaufscheibe 2,0	Clutch washer
144	1	318 001 530		Buchse 7,7	Crankshaft collar
145	1	318 001 330		Schraube 5x14 WS	Pan head screw
147	1	318 001 370		Belüftungsventil	Air vent
148	1	318 001 360		Pumpenantrieb	Gear
149	1	318 001 380		Ölpumpe kpl.	Oil pump assy.
157	1	318 002 150		Spannschraube	Chain adjust screw
158	1	318 001 580		Schraube 4,5x14	Screw
159	1	318 001 350		Ölleitung (A)	Oil pipe
160	1	318 000 920		Schraube 5x14	Screw
162	1	318 001 550		Kettenfänger	Chain catcher
A01	1	318 001 920		Kombischlüssel SW 10/19	Universal wrench
A02	1	952 100 133		Sägekettenschutz	Chain protection cover
				Zubehör (nicht im Lieferumfang)	Accessories (not incl. in delivery)
-	1	941 719 131		Kombischlüssel SW 13/19	Universal wrench



2

Motorgehäuse, Kurbelgehäuse, Zylinder, Zündung
Engine cover, crankcase, cylinder, ignition

3

Vergaser, Luftfilter, Schalldämpfer
Carburetor, air cleaner, muffler

4

Anwerfvorrichtung, Griffe
Starter, handles

5

Kettenbremse, Kupplung, Sägeschiene, Sägekette, Werkzeug
Chain brake, clutch, guide bar, saw chain, tools

	Zeichenerklärung	Key to symbols	Légende
→ 1999999 2000000 → 4/95 → SI 5/95 => xxx = { m* ○ Corr.	Produktion bis Serien-Nr. Neues Teil ab Serien-Nr. Neues Teil ab Monat / Jahr Siehe Service-Information Monat / Jahr Teil gleichwertig ersetzt Nicht mehr lieferbar Keine Serienausführung, jedoch verwendbar Beinhaltet Positions-Nr. Meterware Innensternschraube Druckfehlerberichtigung	Production to serial number New part from serial number New part from Month / Year See Service-Information Month / Year Modified part No more available No standard execution, may be used Contains item no. Sold by the meter Star socket screw Error correction	Production jusqu'à n° de série Nouveau pièce à partir du n° de série Nouveau pièce à partir de Mois / Année Voir Service-Information Mois / Année Pièce modifiée Plus livrable Aucune exécut. en série, cependant utilisable contient n° de numéro Au mètre Vis à étoile intérieure Rectification d'erreurs
	Explicación de símbolos	Verklaring der tekens	Chiarificazione dei simboli
→ 1999999 2000000 → 4/95 → SI 5/95 => xxx = { m* ○ Corr.	Producción hasta N° de serie Pieza nueva a partir de N° de serie Pieza nueva a partir de mes / año Véase inform. servicio mes / año Pieza modificada Agotado No es de serie, pero sirve Contiene pos N° Por metro Tornillo estrella interior Fe de erratas	In productie tot serie-Nr. Nieuw onderdeel vanaf serie-Nr. Nieuw onderdeel vanaf maand / jaar Zie service-informatie maand / jaar Vervangen door gelijkwaardig onderdeel Niet meer leverbaar Geen serieuitvoering, maar wel bruikbaar Omvat Positie-Nr. Metergoed Binnen-ster schroef Drukfoutcorrectie	Produzione fino al n. di serie Nuovo pezzo a partire dal n. di serie Nuovo pezzo a partire dal mese / anno Vedere il servizio inform. del mese / anno Pezzo sostituito con un pezzo equivalente Non più disponibile Non è un modello di serie, ma ugualm. utilizza Comprende la posizione n. Articoli a metraggio Vite con intaglio a stella Rettifica di errori di stampa
	Tegnforklaring	Teckenförklaring	Merkklen selvitys
→ 1999999 2000000 → 4/95 → SI 5/95 => xxx = { m* ○ Corr.	Produktion indtil løbenr. Ny del fra og med løbenr. Ny del fra og med måned / år Se Service-Information måned / år Afløst med tilsvarende del Kan ikke leveres mere Ikke standardudgave, men kan anvendes Inkluderer position nr. Meterware Skruer med indv. stjerne Rettelse af trykfej	Produktion t o m serienr Ny detalj fr o m serienr Ny detalj fr o m måned / år Se serviceinformation måned / år Ersatt med motsvarande detalj Kan ej mera levereras Ej serieutförande, men användbar Innehåller positionsnr Metervara Skruv med stjärnspår Korrigerig av tryckfel	Tuotanto sarjanumeroon ... asti Uusi osa alkaen sarjanumerosta Uusi osa alkaen kuukausi / vuosi Katso huolto-ohje kuukausi / vuosi Osa vaihdettu vastaavaan Ei enää toimitettavissa Ei sarjavalmistusta, voidaan kuitenkin käyttää Positionumero sisältyy Metritavara Tähtikoloruovi Painovirheen oikaisu